

Interpretive Structural Modelling(ISM): a methodology for structuring complex issues

by F. R. Janes, BTech. MSc, CEngg MIIEE, MInstMC - Senior Lecturer, Dept of systems Science, City University, London

Source - Trans Inst MC Vol 10 No 3 August 1988

1. Abstract

This paper discusses the nature of Interpretive Structural Modelling (ISM) as methodology for dealing with complex issues. Aspects of managing complexity relating particularly to the use of ISM with a group of participants are explored. These include the interrelations between the issue, group and methodology, and, between content, context, process and product. Languages for modelling structure are briefly examined, and ISM is presented as a computer-assisted modelling approach incorporating words, graphics and mathematics. The steps of using ISM in practice are considered in the context of group work. Each step is elaborated upon and important features discussed. The use of Nominal Group Technique as an idea-generation method which may be used in conjunction with ISM is outlined. An example of an application is given concerning the structuring of a set of objectives to produce an Intent Structure.

Keywords: Complexity, structure, modelling, digraph, process, group work.

1. Introduction

In creating ISM, J. N. Warfield (1973a; 1974a; and 1976) has developed a powerful methodology for structuring complex issues. Drawing upon discrete or finite mathematics, Warfield has produced a mathematical language applicable to many complex issues, provided that they can be analysed in terms of sets of elements and relations. From the viewpoint of the user, the structural models produced are communicated as a combination of words and digraphs with the mathematics being hidden in a computer program

ISM is particularly useful for working with participants in a group in which structured debate can help the participants to reach a consensus view. The role of a trained facilitator is important here in drawing out different viewpoints and in guiding the group through the steps of the methodology. In this sense ISM attempts to deal with what Flood (1988, in this issue) has labelled '*psychological complexity*' in that it takes into account the different interests and perceptions of the participants. In terms of the classification scheme put forward by Jackson (1988, in this issue) ISM may, for the same reason, be considered as '*pluralistic*'.

Section 2 of this paper deals with a number of aspects of managing complexity in the context of working with groups. **Section 3** examines three languages for modelling structure - words, diagrams and mathematics - and discusses how these are used in ISM. Section 4 deals with ISM as a process and considers the steps involved in building a structural model. In section 5 an application is considered, in this case building an Intent Structure relating to a postgraduate course in Systems Management.

2. Aspects of managing complexity

While ISM may be used by an individual to explore the interrelations between the elements of a complex issue. It has been designed so as to be particularly well suited for group work. In this section a number of aspects of managing complexity will be examined relating particularly to the use of methodologies for group work.

a. Issue, team and tools

In order to investigate a complex issue, it is often both necessary and desirable to assemble a group of people of diverse backgrounds who can work together as a team. The team may include the following four categories of people.

First, *specialists*, with content knowledge relevant to the different aspects of the situation.

Second, *stake holder*:, who may be affected in some way by the outcome of the investigation.

Third, *modellers*, in this case structural modellers who can work with the participants in structuring the issue.

Fourth, a *facilitator*, who can take the participants through the steps of whatever formal group processes are adopted. There may be over-lap between these categories as shown in Fig 1.

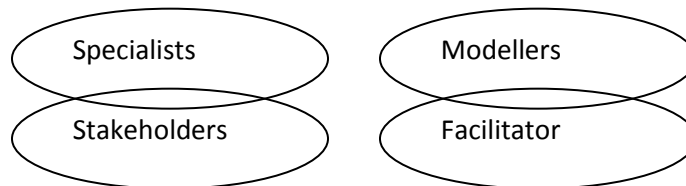

Fig 1 Overlap between categories

The methodological tools adopted to enable the team to explore the issue may be many and varied. Warfield (1976 (ch 1)) has described the interactions between the issue, team and methodology as 'the fundamental triangle of societal problem solving'.

As shown in Fig. 2. the interactions between the three elements themselves give rise to a complex situation that needs careful management. Interaction 1, between the team and the issue, indicates that a group must be assembled that has appropriate involvement of stakeholders and knowledge specific to the issue in order to explore it properly. Furthermore, the participants will have different perceptions of the situation Interaction 2, between the tools and the issue, indicates that a large range of methodological tools may be available to the team, and the appropriate ones for the issue at hand must be selected. Interaction 3,

between the team and the tools, concerns the fact that even if the appropriate tools exist for the issue, the team may not be aware of them or may not understand how to use them.

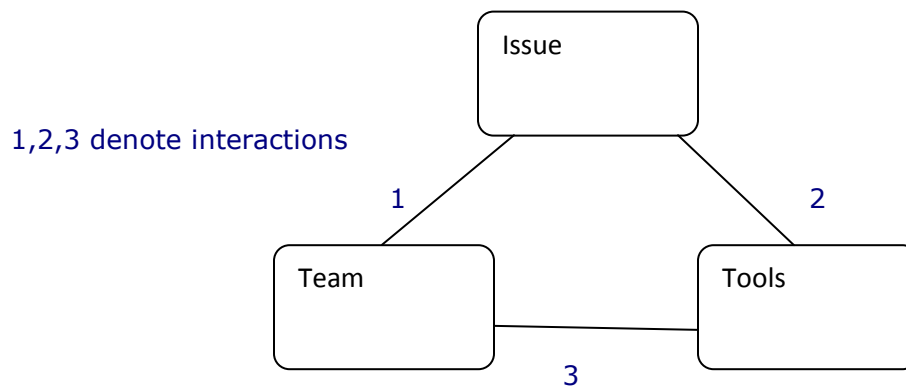

Fig 2 Issue, Team and tools (adapted from Warfield (1976))

(b) Group work

Once methodologies have been selected and a team of people assembled to explore an issue, the workings of a group may be greatly enhanced through a facilitator (Warfield, 1982a) with the necessary technical and behavioral skills. ISM may well be used in conjunction with an idea-generation methodology such as Nominal Group Technique (see section 4(4)). The facilitator needs technical skills in the sense of understanding the process steps of such methodologies and in being aware of the appropriate uses and limitations of the methodologies. He also needs to be familiar with the use of any associated computer software, for example, an ISM program. In addition, the facilitator also needs behavioral skills in management of the group dynamics. He should thus have certain personal skills in dealing with people and should have some experience of group work. Taking a group through the steps of one or more methodologies, keeping the participants focused on the issue and moving the whole process towards a satisfactory conclusion is thus another aspect of managing complexity.

(c) Mental limitations

An important feature of complexity concerns the inter-relations between the multiple elements in the issue being explored. An individual attempting to deal with this complexity encounters mental limitations (Warfield, 1976 (ch 3)). Miller (1956) thought that the span of immediate recall was in the region of 7 (+-) 2 'chunks' of information, while Simon (1974) concluded that the 'chunk capacity of the short-term memory' was in the range of 5 to 7. A system having only three variables each of which has a two-way interrelation with every other variable, may be considered in terms of 9 chunks of information (Wailer. 1982). In principle, this exceeds the limits of the ability of our short-term memory to deal with it (Fig 3).

3 Variables, 6 relations
= 9 Chunks

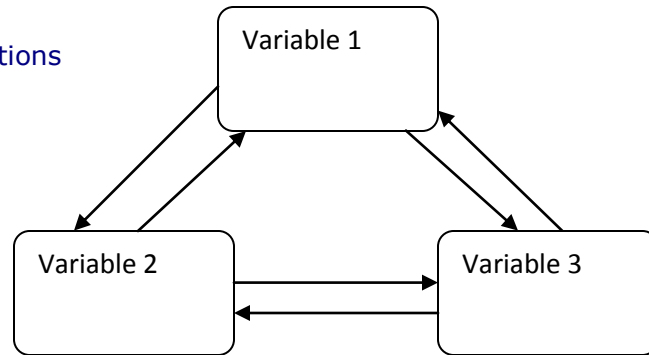

Fig 3 Chunks of information

Any methodology for dealing with complex issues must, therefore, be able to break complexity down into manageable chunks of information so that the human mind can deal with it. ISM tries to do this, by enabling an individual or group to focus on the interrelations between

two elements in an issue at a time, without losing sight of the properties of the whole.

(d) Content, context, process and product

Investigation of an issue or problem by a group will be aided if due attention is paid to content, context and process (Warfield, 1982b; 1984). *Content* consists of information related to the issue, particularly knowledge that the individual members of the group have about a situation and their differing perceptions of the issue or problem. Content does not exist in isolation but will depend upon an *issue context* including, for example, the particular situation and people involved in it (Fig 4). *Process* involves activities, in particular the steps of the methodology(ies) through which the group progresses when, for example, generating and structuring ideas. This process will be carried out in a *process context* consisting of the facilitator and supporting environment (physical and human) in which the group works. The outputs of the process may be regarded as the products resulting from the work - eg structural models - and the *learning* which takes place among the participants during the sessions.

From the above it will be seen that investigating a complex issue may place a considerable requirement upon those conducting the inquiry. A relevant group has to be assembled, methodologies must be selected, the group must be managed and attention paid to both process and contexts as well as to content and products. This will all help to ensure that appropriate products are produced and that beneficial learning takes place among the participants.

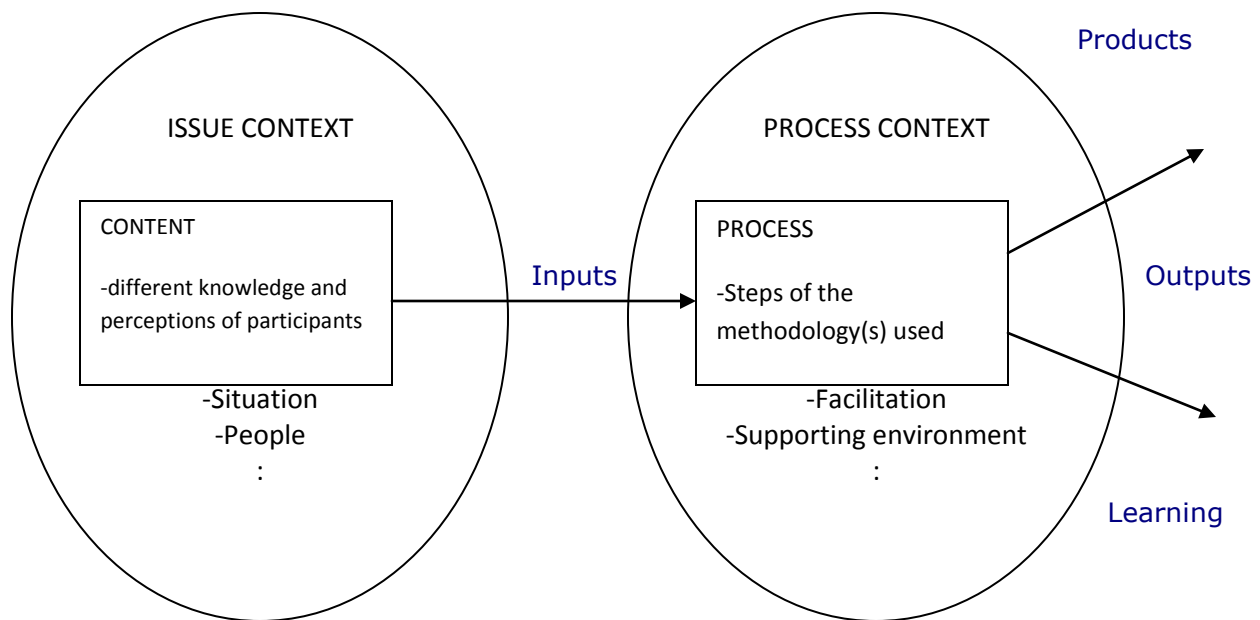

Fig 4 Content context, process and product

3. Languages for modelling structure

In the context of ISM, the term *structure* is used to denote the particular set of elements identified as being of interest in a problem or issue and the pattern of interrelations between them. Three modelling languages of particular importance in representing the structure of complex systems are: words; diagrams; and mathematics. In this section they are briefly examined together with their role in ISM.

(a) Modelling languages

Words may be used to construct a linguistic model of structure subject to the rules of grammar and semantics relevant to the particular natural language. They provide a most elaborate method of representing and communicating the structure of a system symbolically (Mihram. 1972).

Diagrams offer a pictorial representation and, like words, largely provide qualitative models. However, diagrams make full use of the parallel information processing capacity of the visual system and thus provide a very powerful means of communication. This contrasts with linguistic models which have their origins in the spoken word and, even though they may be read with the eye, are essentially a serial way of conveying information evolved to be compatible with the ear: a serial information-processing machine.

Mathematics makes it possible for symbolic models to be constructed which are manipulated entirely by a mathematical formalism such as calculus or algebra. This allows quantitative representation and a great deal of manipulation to be undertaken. However,

such models are limited, as a means of communication, to those who understand the particular mathematical language.

In developing ISM, Warfield (1976) has combined words with digraphs, a specific form of diagram, in order to provide an easy means of representing and communicating complex structural models. The construction of such models by a user group may involve considerable mathematical manipulation, but this can be entirely hidden from the user in a computer program. ISM uses the discrete mathematics of logic and structure (including binary relations, set theory, matrix theory, graph theory and Boolean algebra) which is particularly suitable for representing systems described in terms of elements and relations.

(b) Interpretive structural models

Directed graphs or digraphs are well suited to represent complex structures diagrammatically. In ISM the vertices of the digraphs represent the elements of the issue or problem being studied, while the edges are directed and denote a specific relation between the elements. For example:

Elements	Relation
1. Factors in running a successful business	- strongly contributes to
2. Objectives of an organisation	- would help to achieve
3. Planned county road schemes	- is better value for money than

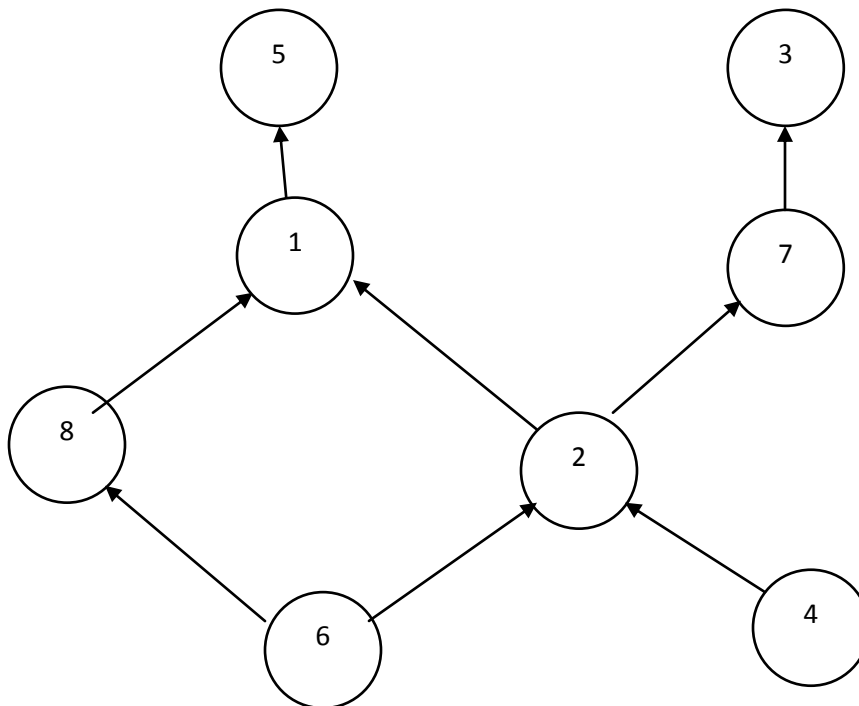

Fig 5 Example of a digraph

Fig 5 shows a section of a typical digraph for example 2 above, in which the circles represent the objectives and the arrow represents the phrase 'would help to achieve'. Inserting the wording of the elements in place of the numbered circles give a well defined structural model based on words and digraphs which is easily communicated. An example of this is shown in Fig. 12.

Warfield (1982b) has described ISM as "a computer-assisted learning process that enables an individual or a group user to develop a structure or map showing interrelations among previously determined elements according to a selected contextual relationship'. The process of ISM forces the user to select the elements of importance in the issue being explored and to state explicitly the interrelations between them according to a specific contextual relation. The resultant ISM is a user-created visual model showing elements and relations as a multilevel digraph. The user may be an individual or a group. and the process may be done manually. which can be laborious, or with a computer equipped with ISM software. However, the full potential of the methodology is best realised in a group context with a computer.

Waller (I 983) has described ISM as context free in that it can be used in any complex situation. irrespective of the content of the situation, provided that a set of elements can be identified and an appropriate contextual relation defined. Furthermore, the elements may be qualitative or quantitative, permitting items to be included which are not measurable on anything other than ordinal scales of measurement. In this sense ISM is much more flexible than many conventional quantitative modelling approaches which require variables to be measurable on ratio scales. ISM thus offers a qualitative modelling language for structuring complexity and enables a group of users to map their thinking on an issue by building an agreed structural model.

4. The Interpretive Structural Modelling process

Building an Interpretive Structural Model involves a number of activities. and these are summarised in this section. The exact sequence of steps will vary from situation to situation. but the process shown in Fig 6 is typical of the full sequence when ISM is used to explore a complex issue with a participant group using a computer.

(1) *Identifying issue to be studied.* It is necessary to identify fairly clearly the particular issue which is to be explored using ISM. An organisation may (or example, be concerned about the inadequacies of its strategic planning. It may see ISM as a methodology which can be used to involve managers in examining the interrelations between a set of organisational objectives in order to set priorities or assist in organisational design.

(2) *Deciding on type of ISM to be constructed.* At this stage it is usually important to decide on the type of structure which is to be produced during the ISM session. This will help co determine the form in which the elements are to be generated. if they are not already known, and the likely wording of the contextual relation which will be used to interrelate the elements.

Warfield (1982a) has classified the structures resulting from the application of ISM into five types. An Intent Structure shows the interrelations between a set of objectives. A typical contextual relation for such a structure might be 'would help to achieve'. Such structures have a number of uses (Warfield. 1973b) including clarifying thinking, explaining what an organisation or project is trying to accomplish, and providing a basis for taking action. A

Priority Structure can be constructed when it is required to rank a number of elements in order of priority. The elements might, for example, be a list of planned local authority projects.

1. Identify issue to be studied
2. Decide on type of ISM to be constructed
3. Select participant group and facilitator
4. Generate the element set
5. Complete matrix of element interactions
6. Display the ISM
7. Discuss structure and amend if necessary

Fig 6 Process of interpretive structural modelling

An associated contextual relation might then be: 'is more important than'; or 'is better value for money than'. Such structures are clearly of use in allocating limited resources. An *Attribute Enhancement Structure* shows the interrelations between a set of factors, problems or opportunities. A contextual relation 'strongly contributes to' might be used, for example, to explore the interrelations between a set of problems facing a manufacturing company. The remaining two types of ISM are *Process Structures* which usually involve some kind of sequencing of a set of activities and *Mathematical Dependence Structures* which may be used to map the interrelations between a set of quantifiable elements.

(3) *Selecting participant group and facilitator.* In section 2(a) the categories of people who might form a team for an ISM session were considered. The selection of particular individuals will depend on the situation. Clearly, it is essential that participants have the necessary content knowledge relevant to the issue. If the ISM is being done for an organization, the involvement of stakeholders, including decision makers, will help to ensure commitment to the outcomes, eg, in the case of Priority or Intent Structures.

One important consideration is group size. The group of participants responding to the questions put by the computer should be limited to a maximum of around eight people. As the group size increases much above this number, the quality of debate deteriorates. Since each member can converse with every other, the number of possible communications between different individuals in a group of n people is $n(n - 1)$. An increase in the group size from six to ten participants thus results in the number of possible communications trebling from 30 to 90 (Fig 7). Individual participation, involvement in the process, and interest consequently tend to decline.

As discussed in section 2(b), the process facilitator plays an important role and he needs to have the necessary technical and behavioral skills to guide the group during the ISM session. It is highly desirable that the facilitator be familiar with building structural models and he may be assisted both by other modellers and a computer operator if the resources permit.

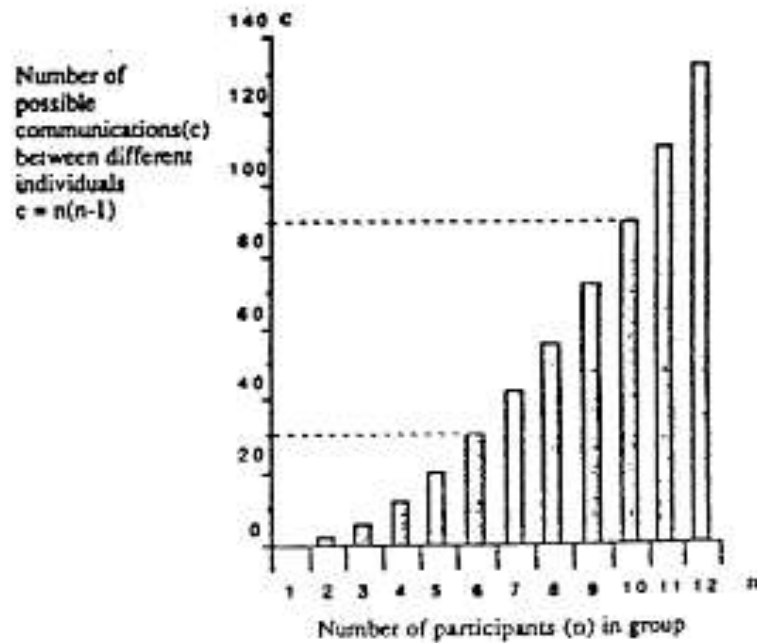

Fig 7 Possible communications between different participants

(4) *Generating the element set.* In some cases the set of elements to be structured may already be defined. For example, they may be a set of county highway schemes, which have to be prioritised because the financial resources to carry them all out are not available. However, in many cases it will be desirable and necessary for the participant group to generate the elements. For example, when developing an Intent Structure for a department in an organisation, the managers involved may first have to generate the objectives to be structured. Similarly when, say, using ISM to explore how the factors influencing the effective implementation of a major construction project contribute to one another, the participants will probably have to generate the factors in the first place.

The use of structured idea-generation methods is one way in which a group can produce the necessary set of elements. Nominal Group Technique (NGT) invented by Delbecq et al (1975) is a process that has been found to work particularly well in conjunction with ISM (Janes, 1987; Moore, 1987; and Wood and Christakis, 1984), Warfield (1982b) has described NGT as 'an efficient method for generating ideas in groups, for clarifying the generated ideas, for editing the generated ideas, and for developing a preliminary ranking of the set of ideas'. The process may be described in terms of five basic steps:

- (i) clarification of a trigger question;
- (ii) silent generation of ideas in writing by each participant;

- (iii) round-robin recording of the ideas on a flipchart;
- (iv) serial discussion of each idea for clarification and editing; and
- (v) voting to obtain a preliminary ranking of the ideas in terms of importance.

Step (iii) ensures that all ideas are recorded and step (iv) enables a full discussion of the ideas generated in order to clarify and edit them. The process is thus fairly exhaustive and ensures that all participants have a clear understanding of, and opportunity to express value judgements on the ideas produced.

(5) *Completing a matrix of element interactions.* At this stage the ISM software can be used. The set of elements to be structured is entered into the computer and the group is asked to respond to a series of questions put by the computer of the form:

'Is the Wilton Road Dual Carriageway better value for money than the Chester Abbots Bypass, taking into account all the benefits and capital costs:

In this example a Priority Structure is being developed for a set of highway improvement schemes using a contextual relation 'is better value for money than', qualified with a phrase related to benefits and capital costs. In the case of an Intent Structure, a typical form of question is:

'Would the objective of improving the quality of products help to achieve the objective of reversing the decline in profits?'

Here, an *Intent Structure* is being developed for a set of organisational objectives in a manufacturing company using the contextual relation 'would help to achieve'.

In either case the group discusses the question under the guidance of the facilitator and a 'Yes' or a 'No' answer is agreed upon after a vote has been taken by the participants. When the group votes for a 'Yes' a '1' is entered in the appropriate cell of a matrix in the computer. A 'No' vote results in a '0' being entered. The binary matrix being constructed represents a binary relation of a set on itself. As the process proceeds, the computer makes logical inferences, based upon the answers already given, which speeds up the process and leads to the construction of a reachability matrix (Warfield, 1976 (ch 9)). An example is shown in Fig 8.

	e1	e2	e3	e4
e1	1	1	0	1
e2	0	1	0	0
e3	1	1	1	1
e4	1	1	0	1

e1, e2, e3, e4 denote elements

matrix entries : 1 = 'yes'
0 = 'no'

Fig 8 Example of a simple reachability matrix

The '1' entries signify that a relation exists between a pair of elements. for example, cell (e3, t1). A '0' entry signifies that no significant relation exists. for example, cell(e2, e4).

The mathematics underpinning ISM always assumes that the contextual relation used is transitive, which permits transitive logical inferences to be made by the computer. It is thus important that care is taken in selecting the contextual relation to ensure that it has this property of transitivity. An example is shown in Fig 9a for the contextual relation 'is a higher priority than'. Since project A is a higher priority than project B, and B is a higher priority than C, then it can be transitively inferred that A is a higher priority than C.

In some cases the relation used may also have other logical properties, such as asymmetry which allows asymmetric inferences to be made. An example is shown in Fig 9b for the relation 'precedes'. Since step A precedes step B, it can be asymmetrically inferred that step B cannot precede step A. The total number of inferred answers in an ISM session will vary from one situation to another, but may typically be of the order of 70%. This represents a considerable time saving when dealing with, say, 20 elements and hence a 20 x 20 matrix with 400 cells to fill in.

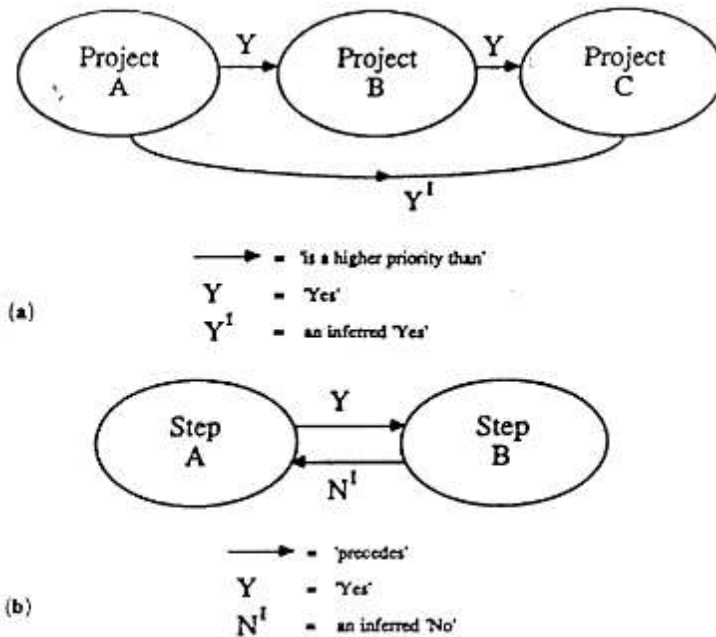

Fig 9 (a) Example of a transitive logical inference. (b) Example of an asymmetric logical inference

(6) Displaying the ISM. When all necessary questions have been answered by the group and a *reachability matrix* constructed, the computer can extract a multi-level digraph from the matrix. Fig S gave an example of such a digraph, in that case a hierarchical digraph containing no cycles. A multi-level digraph with cycles is shown in Fig 10. The theory underlying the process of extracting such digraphs from reachability matrices involves extensive use of discrete mathematics. For further information on this the reader is

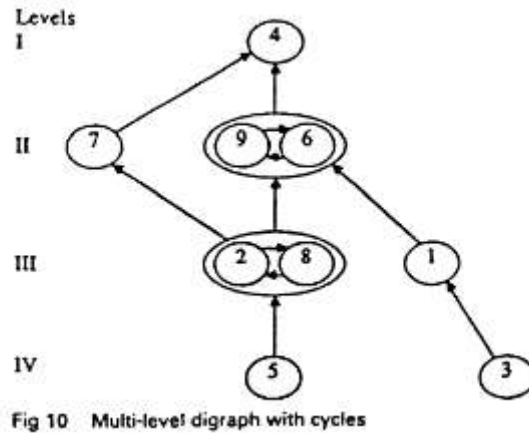

Fig 10 Multi-level digraph with cycles

Fig 10 Multi-level digraph with cycles

referred to Warfield (1973cl. or Warfield (1976 (ch 10)). However, to demonstrate the concept, it may be seen by inspection that the multi-level digraph in Fig 11a corresponds to the simple four element matrix in Fig 8. This may be redrawn with transitive relations deleted to give the minimum-edge digraph in Fig 11 b.

The ISM may now be displayed to the group. This involves substituting the full elements in words for the numbered circles in the digraph. Section 5 gives an example of such an ISM. It is desirable that the display be in a flexible form at this stage to enable the group to discuss and amend it, if necessary. This can be done by, for example, writing each element on a separate 'Post-it' sticker or index card and displaying the structure on a large whiteboard.

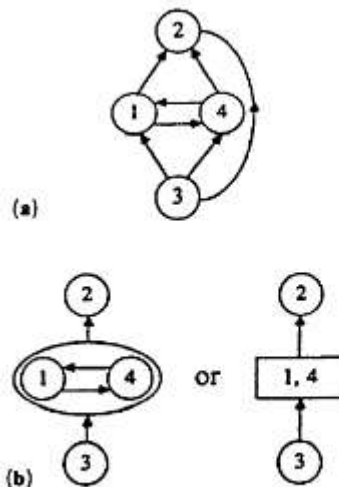

Fig 11 (a) Digraph corresponding to matrix of Fig 8.
 (b) Minimum-edge digraph for Fig 11a

Fig 11 (a) Digraph corresponding to matrix of Fig 8.

(b) Minimum-edge digraph for Fig 11 a

(7) *Discussing and amending the structure.* At this stage, the session facilitator, or another member of the modelling team, should take the group through a discussion of the ISM. The purpose of this is to explain the structure to the participants so that they understand clearly how to interpret it, and to allow them to express their views on it. Participants may suggest that amendments are made to the structure. These are normally fairly minor, typically involving, say, the movement of an element to a new position or the deletion of a relation. The facilitator should be careful to explain any proposed changes to the group and to encourage discussion of them. He may find it helpful to refer back to the record of 'Yes' and 'No' answers given by the group to the questions put by the computer. Changes should only be made if there is a reasonably strong desire among a majority of the participants to do so, since the structure is synthesised through a systematic process of discussion, and argument. However, changing elements and relations at this stage is, not in any way a negation of the structure. The ISM process is a learning process, and people's perceptions may change during the session as the result of argument or new information emerging. They may thus wish to revise a decision made earlier in the session. Agreed amendments may be fed into the computer and the ISM updated. The model can then be expanded at a later stage if necessary.

It is often useful to give the group an opportunity to discuss the model at an intermediate stage after, say, the first 8-10 elements have been structured. If they are new to the process, this gives them a feel for the kind of model being produced. It also allows minor corrections to be made by the group at an early stage, if desired, and ensures an agreed foundation on which to build.

In some cases, a large number of elements have to be structured in a limited time. It may then be desirable to select a representative subset of, say, 20 for structuring vigorously

an a computer-assisted ISM session and to place the remainder into the ISM by hand. This works particularly well with Priority Structures (Moore, 1987)

5. Application of ISM

Warfield (1982a) lists a wide range of situations in which ISM has been applied covering all five types of structure described in section 4(2) of this paper. The majority of these are Intent and Priority Structures which appear to be particularly effective uses of ISM. This has certainly been the author's own experience in using ISM professionally within a range of UK organisations, including the Metropolitan Police, Hertfordshire County Council, the Engineering Industry Training Board, the Institution of Mechanical Engineers, the Royal Navy and City University. In this section an example is given of an application of ISM.

(a) Building an Intent Structure for a postgraduate course

The particular application discussed concerns a postgraduate course in Systems Management developed jointly between industry and a university. The course has been designed for able young engineers working in industry who, as their careers progress, find themselves responsible both for other engineers and complex manufacturing operations. It is thus about systems management in the broad sense of managing complex systems of men and, machines in a rapidly changing technological environment. The course involves intensive periods of study at the university concerned and a major project in the student's own company. All students on the course are sponsored by their own organisations.

As part of the design process for the course, an Intent Structure was constructed. Nominal Group Technique was used to generate the elements for the ISM following the steps described in section 4(4) of this paper. Eight participants were involved, including five senior engineering managers representing the industrial steering committee responsible for the course and three academics representing the university department involved. The NGT trigger question used to focus the generation of ideas was:

'What does industry perceive that the students should achieve during the twelve months of the Systems Management course?'

The resulting ideas were essentially a set of objectives expressed in terms of what the students should achieve during the course. After completion of the NGT, during which the initial objectives were clarified, edited and ranked for importance, it was agreed that 30 of them would be structured in the subsequent ISM session.

In this case the contextual relation used to examine interrelations between the objectives was the phrase 'would strongly contribute to'. The ISM process thus required participants to respond to a series of questions put by the computer of the form:

'Would development of an enhanced communication ability strongly contribute to the development of self-confidence and leadership qualities?'

As the process proceeded, the computer built up an ISM 'map' portraying the group's perceptions of the interrelations between the elements. The map was extracted from the computer, displayed and discussed several times during the four-hour ISM session. Fig 12 shows the completed 30 element map as an Intent Structure.

(b) Interpretation of the Intent Structure

The boxes in the map contain the objectives with the original NGT numbering scheme. The arrows between the boxes represent the relation 'would strongly contribute to'. The Intent

Structure thus shows what strongly contributes to what.

Paths. A sequence of objectives connected by arrows is known as a path on the map. For example, the path 26 - 4 - 1 IS explicitly shown. This may be interpreted as a statement that objective 26 strongly contributes to objective 4 and that 4 contributes to 1. However the transitive nature of the map means that 26 may contribute directly to any elements which it reaches via a path of one or more arrows –eg objectives 4,1,39,14,10,16, etc. A similar interpretation may be made regarding the interrelations between the other objectives on the map.

Cycles. There are a number of cycles on the map indicated by the black asterisks. Consider, for example, the cycle between 37 and 8. This implies both that 37 contributes to 8 and that 8 contributes to 37.

Levels. The Intent Structure may be partitioned into three broad levels as indicated on the right-hand side of the map. The lowest level consists of objectives largely concerned With 'Concept Formation and Attitude Change'. The second level contains the 'Enabling Skills' objectives related to systems design, computing, communication and leadership. The third level has been labelled 'Output Characteristics', being concerned with the abilities and characteristics of the student after completion of the course, together with the student's impact on his or her own company.

Sub-groups. Many of the objectives fall fairly clearly into sub-groups as shown in the digraph of Fig 13. Five main sub-groups are identified which are concerned with:

- the systems approach;
- systems design skills;
- computer-related skills;
- leadership qualities; and
- own-company impact.

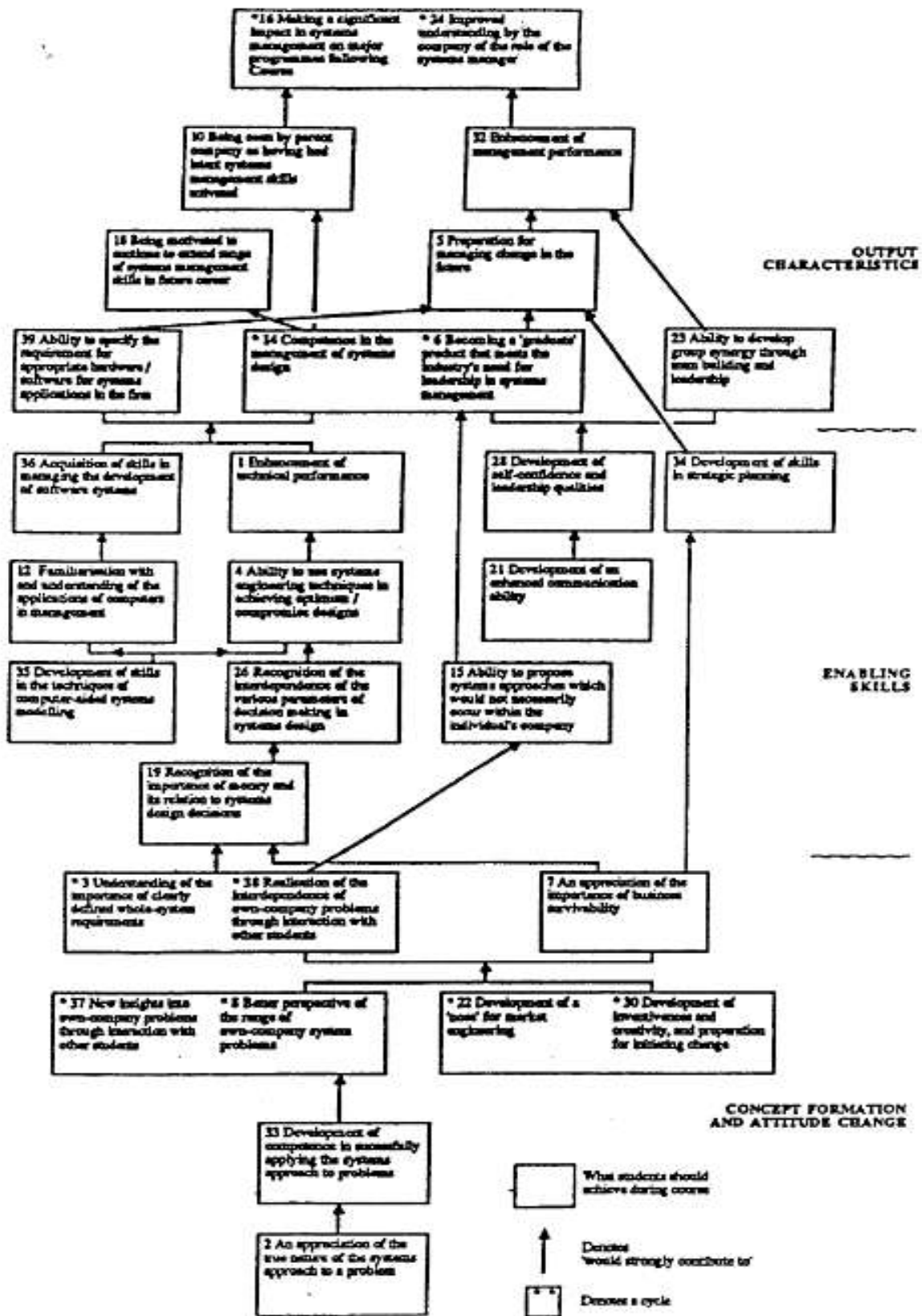

Fig 12 ISM Intent Structure for students on systems management course

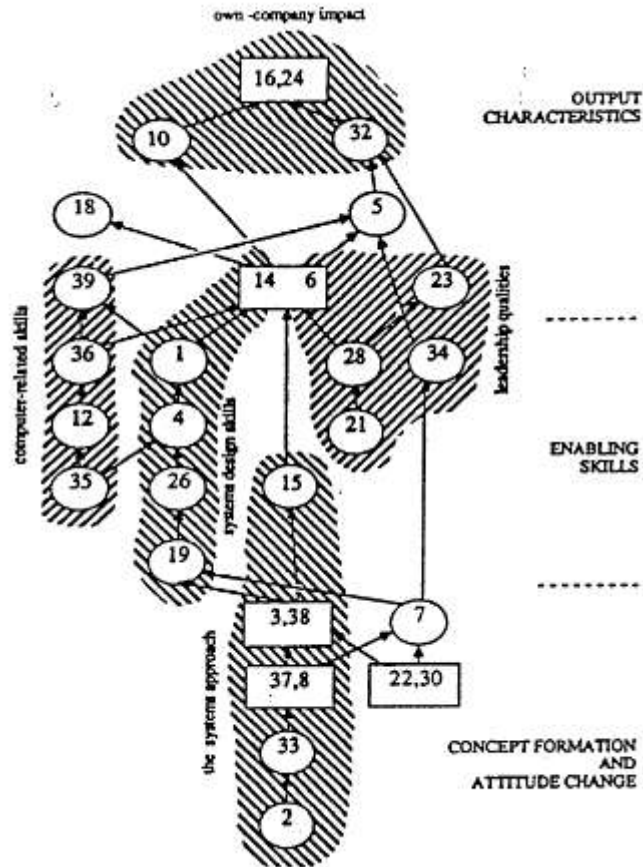

Fig 13 Major sub-groups and levels in structure

(c) Uses of the Intent Structure

The construction of such an Intent Structure helped in the following ways:

- Making explicit the multiple objectives of the course and their implications for its design and management.
- Clarifying thinking through asking participants to think through the complex interactions between the objectives systematically.
- Team building and generation of some planning momentum.
- As a way of explaining the purpose of the course to those involved and to any relevant outside agencies.
- As a basis for course planning. The levels and subgroups which emerge from the structure and the interrelations between the objectives provide useful information for this purpose.

- Assisting with syllabus design and scheduling.
- As a way of assessing and reporting progress. Many objectives may be followed at the same time and effort may be switched between them.
- As a base from which to change objectives as new ideas are developed or as circumstances change.

6. Conclusions

ISM combines three modelling languages: words, digraphs and discrete mathematics, to offer a methodology for structuring complex issues. It readily incorporates elements measured on ordinal scales of measurement and thus provides a modelling approach which permits qualitative factors to be retained as an integral part of the model. In this it differs significantly from many traditional modelling approaches which can only cope with quantifiable variables.

In this paper 'SM has been described in the context of working with a group of participants having access to ISM software on a computer. The steps of ISM have been described as a process taking place within a process context. The inputs to the process are the different knowledge and perceptions of the issue owned by the participants. This content knowledge will itself exist within an issue context. The process yields outputs in the form of products and learning by the participants- The role of a facilitator when using such a methodology is important in guiding the group through the steps of the process and keeping them focused on the issue so as to ensure the most productive use of their time.

A number of benefits accrue from the use of ISM. These include focused debate, clarification of thinking. group learning and team building. In addition there is an emphasis on clarifying terms and clear specification of relations so that the user-created visual model are easily understood.

ISM may be used on its own when the elements of the issue are already known. Where this is not the case, Nominal Group Technique may be introduced as one step in the ISM process to assist the participants in generating and clarifying the elements to be structured. When used together, NGT and ISM provide a powerful methodology for structuring complex issues. The application examined deals with an Intent Structure for a post-graduate course. However, the methodology is applicable in many situations in which a participant group wishes to gain a better understanding of a complex issue.

Acknowledgements

The author is grateful to the following people: J. N. Warfield, A. N. Christakis and R. J. Waller for sharing their ideas in discussions on ISM; P. K. M'Pherson for contributions to the application discussed; and R. J. Jeffery for assistance with the figures in the paper.

References

- Delbecq**, A. L et al 1975. *Group techniques for program planning*. Scott, Foresman and Company. Glenview, Illinois, USA.
- Flood**, IL L 1988. 'Situational complexity. systems modelling and methodology'. *Trans Inst Meas & Cant.* 10(3)122-129.
- Jackson**, M. C 1988. 'Systems methodologies as complementary tools for managing situational complexity', *Trans Inst Meas&Cont*, 10(3). 155-160.
- Janes**, F. L 1987. 'Applications of interactive management in planning for engineering education'. In: *Problems of constancy and change. Vol 1*, 31st Ann Meet int Soc for Gen Syst Res, Budapest. June, 520-525.
- Mihram**, G. A. 1972. 'The modelling process'. *IEEE Trans on Syst, Man and Cybern.* SMC 2(5), 621-629.
- Miller**, G. A. 1956. 'The magical number seven, plus or minus two: some limits on our capacity for processing information'. *Psych Rev.* 63(2), 81-97.
- Moore**, C. M. 1987. *Group techniques for idea building* - Sage publications, London.
- Simon**, H. A. 1974. 'How big is a chunk?' *Science*, 183 (8), 482-488.
- Waller**, IL J. 1982. 'Complexity and the boundaries of human policy' making'₁ *Intl Gen Syst*, 9, 1-11.
- Waller**, R. J. 1983. 'Knowledge for producing useful knowledge'. In: Kilman, IL H. et al (eds). *Producing knowledge for organisations' Vols I and II*, Praeger, New York, USA.
- Warfield**, J. N. 1973a. *An assault on complexity*, Battelle Monograph No 3, Battelle Memorial Institute, Columbus. Ohio, USA. Warfield, J. N. 1 973b. 'Intent structures'. *IEEE Trans on System, Man and Cybeni*, SMC3(2), 133-140.
- Warfield**, J. N. 1973c. 'Binary matrices in systems modelling; *IEEE Trans Syst, Man and Cybern*, SMC 3 (5), 441-449.
- Warfield**, J. N. 1974a. *Structuring complex systems*, Battelle Monograph No 4, Battelle Memorial Institute, Columbus. Ohio, USA.
- Warfield**, J. N. 1974b. 'Developing subsystems matrices in structural modelling', *IEEE Trans Syst, Man and Cybem.* SMC 4(1), 74-80, 81-87.
- Warfield**, J. N. 1976. *Societal systems: planning. policyand complexity*, John Wiley & Sons Inc. New York, USA.
- Warfield**, J. N. 1982a. 'Interpretive structural modelling'. In: Olsen, S. A. (ed), *Group planning and problem solving methods in engineering management*. John Wiley and Sons, Inc, New York, USA.
- Warfield**, J. N. 1982b. 'Organisations and systems learning'. *Gen Syst*, 27,5-74.
- Warfield**, J. N. 1984. 'Principles of interactive management', *Proc mt Conf on Cybern and Soc*, IEEE. New York. USA.
- Wood**, W. C. and Christakis, A. N. 1984. 'A methodology for conducting futures orientated workshops'. *Technology Forecasting and Social Change.* 26,281-297.